



MODEL H0582 1" HEAVY-DUTY PIN-CLUTCH IMPACT WRENCH INSTRUCTION SHEET

⚠ WARNING	
	EYE/EAR INJURY HAZARD! Wear safety glasses and hearing protection when using this tool!
	INJURY HAZARD! Always disconnect tool from air to prevent unexpected operation during service!
	DO NOT EXCEED 120 PSI! Personal injury could occur.
	SHATTERING HAZARD! Use sockets rated for impact wrench use only.

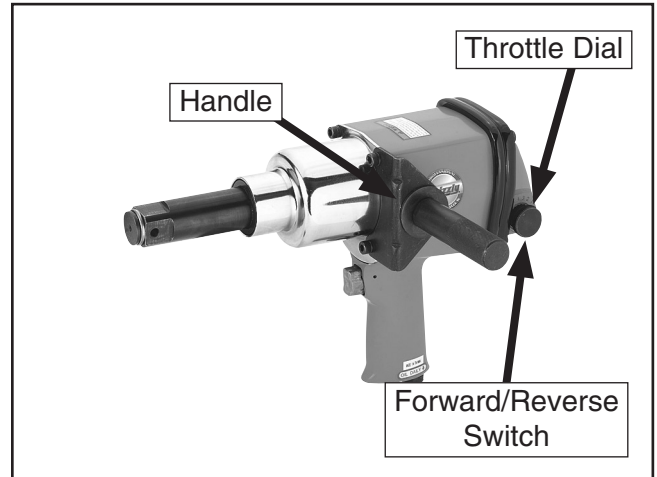

Figure 1. Model H0582

Specifications

Drive Size	1"
Bolt Size Capacity	1 3/4"
No-Load Speed	3,800 RPM
Maximum Torque	1,200 ft/lb
Air Inlet Size	1/4" NPT
Air Consumption	12 CFM
Operating Pressure	90 PSI
Maximum Operating Pressure	120 PSI
Weight	12.75 lbs

Inventory

A. Impact Wrench	1
B. Handle	1
C. Nut	1

Setup

Secure the handle to the impact wrench with the nut, so the assembled tool looks like **Figure 1**.

If you need help with your new pneumatic tool, call our Tech Support at: (570) 546-9663.

Operation

For best performance, connect your wrench to the air supply with a 1/2" air line and fittings. Slide the forward/reverse switch left or right to make the wrench turn clockwise or counterclockwise. Adjust the throttle dial to increase or decrease torque.

Maintenance

The impact wrench **MUST** be regularly lubricated with 3-4 drops of air tool oil directly into the air fitting before each use. For best results, we recommend using an in line filter, lubricator, and regulator, as shown in **Figure 2**.

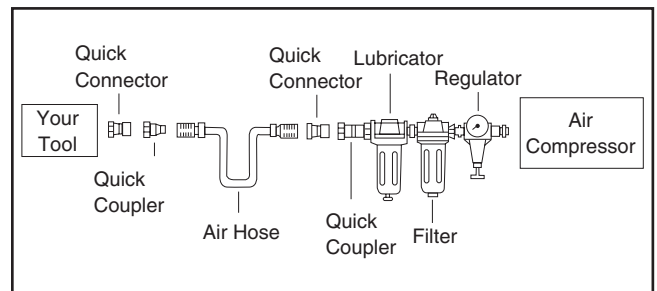

Figure 2. Installing your tool.

COPYRIGHT © OCTOBER, 2008 BY GRIZZLY INDUSTRIAL, INC.

WARNING: NO PORTION OF THIS MANUAL MAY BE REPRODUCED IN ANY SHAPE OR FORM WITHOUT THE WRITTEN APPROVAL OF GRIZZLY INDUSTRIAL, INC.

#TR11306 PRINTED IN TAIWAN

*H0582 Parts Breakdown and List

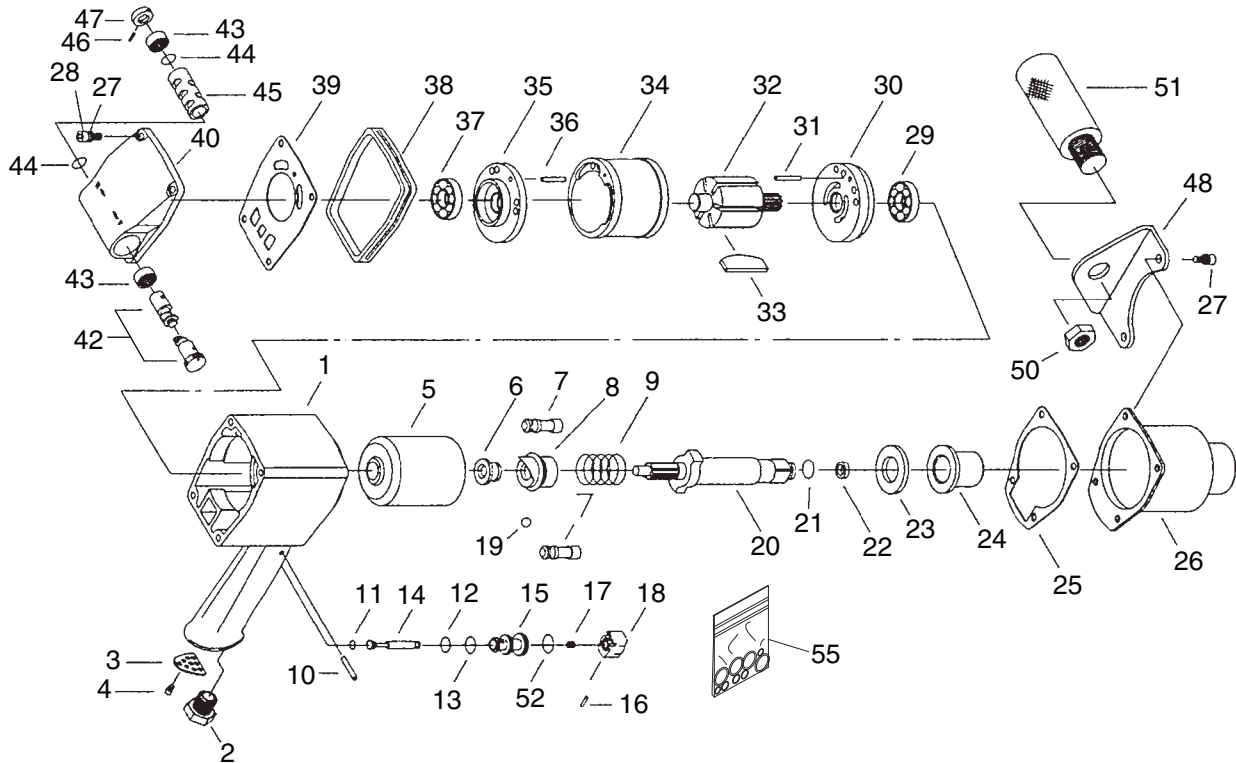

REF	PART #	DESCRIPTION
1	PH0582001	HOUSING
2	PH0582002	AIR INLET
3	PH0582003	EXHAUST DEFLECTOR
4	PH0582004	SCREW
5	PH0582005	HAMMER CAGE
6	PH0582006	DRIVE CAM BASE
7	PH0582007	HAMMER PIN
8	PH0582008	DRIVE CAM
9	PH0582009	SPRING
10	PH0582010	ROLL PIN
11	PORP004	O-RING 3.8 X 1.9 P4
12	PORP009	O-RING 8.8 X 1.9 P9
13	PORS012-5	O-RING 12 X 1.5 S12.5
14	PH0582014	VALVE STEM
15	PH0582015	VALVE BUSHING
16	PH0582016	SCREW
17	PH0582017	VALVE SPRING
18	PH0582018	TRIGGER
19	PH0582019	STEEL BALL
20	PH0582020	ANVIL
21	PORS016	O-RING 15.5 X 1.5 S16
22	PH0582022	ANVIL COLLAR
23	PH0582023	SPACER
24	PH0582024	BUSHING
25	PH0582025	GASKET
26	PH0582026	HAMMER COVER

REF	PART #	DESCRIPTION
27	PH0582027	SCREW & SPRING WASHER
29	PH0582029	BALL BEARING
30	PH0582030	FRONT END PLATE
31	PRP15M	ROLL PIN 3 X 8
32	PH0582032	ROTOR
33	PH0582033	ROTOR BLADE
34	PH0582034	CYLINDER
35	PH0582035	REAR END PLATE
36	PRP37M	ROLL PIN 3 x 14
37	PH0582037	BALL BEARING
38	PH0582038	HOUSING BAND
39	PH0582039	GASKET (A)
40	PH0582040	REAR COVER
42	PH0582042	REGULATOR (A & B)
43	PH0582043	REGULATOR BUSHING
44	PORP018	O-RING 17.8 X 2.4 P18
45	PH0582045	VALVE BUSHING
46	PRP17M	ROLL PIN 3.5 X 24
47	PH0582047	REVERSE VALVE KNOB
48	PH0582048	PLATE
49	PW02	FLAT WASHER 3/8
50	PN09M	HEX NUT M12-1.75
51	PH0582051	HANDLE
52	PORP014	O-RING 13.8 X 2.4 P14
† 55	PH0582055	COMPLETE O-RING KIT

* Not all parts shown are available for purchase.

† Not included; item shown for aftermarket purchase only.